

Congratulations!

The HTB-504 Home Theater System will make watching movies at home more fun than ever. To connect your speakers to the receiver follow the instructions on this sheet. To learn how to operate your receiver please read and follow the instruction manual included in the receiver's box. If you're also connecting other equipment, such as a TV, VCR, DVD player, CD player or other source component, use the receiver's manual in combination with the manuals that came with those components.

Placing Your Speakers

Place the speakers as shown in the diagram below. While you're setting the speakers up, keep these points in mind:

- If the subwoofer causes discoloration of the TV picture, move it away from the TV until the discoloration disappears.
- Since the center speaker is magnetically shielded, you can place it right on top of the TV without worrying about picture discoloration.
- You can hang the surround speakers on the wall using heavy-duty picture-hangers.
- Placing the subwoofer next to a wall yields more deep bass output than placing it away from a wall. Placing the subwoofer in a corner yields the deepest bass output overall.

The subwoofer will sound good just about anywhere in the room.

Place the center speaker above or below the center of your TV. Angle it down or up to aim it directly at the listeners.

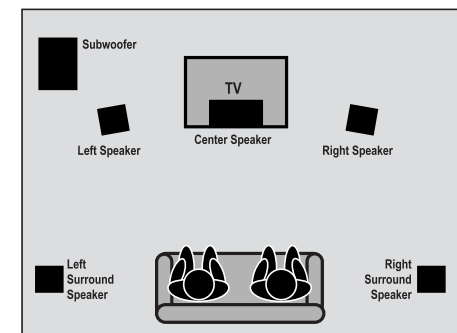

Place the left and right speakers on each side of your TV. Angling them towards the listeners improves the stereo effect.

Place the surround speakers as high as possible, directly to the sides of the listening area, pointing at the listeners.

Connecting Your Speakers

Important: Do not plug the receiver and subwoofer's power cords into AC outlets until you have properly connected all of the speakers.

Connect the speakers as shown in the main diagram.

In each case, connect the colored speaker wire to the red terminals on the speaker and receiver, and connect the black speaker wire to the black terminals on the speaker and receiver.

To make connecting the speakers easier, we have color-coded the speaker wire and the terminals on the speakers, labeled the terminals on the receiver, and pre-stripped the insulation from the ends of the wire.

The subwoofer connects to the receiver using the black audio cable:

- Connect one end of the black audio cable to the input connector on the subwoofer labeled **L/MONO**, and connect the other end to the connector on the receiver labeled **SUB WOOFER PRE OUT**.

Using your Subwoofer

Your SW-35HT subwoofer has features that make it easy to set up and use.

Auto Power On/Off

After you turn the subwoofer's power switch On for the first time, the subwoofer's Auto Power On/Off feature will put the subwoofer into Standby when you're not using it and turn it On again when you use your system. (When the subwoofer is On the indicator on its rear panel glows green. When the subwoofer is in Standby the indicator glows red.) If you will not be using your system for an extended period of time we recommend that you turn the subwoofer's power switch Off.

(HTB-404 Quick-Connect Guide on other side)

Crossover Filter Switch

Since your receiver has a built-in crossover (circuitry that separates the bass from the rest of the sound) on its subwoofer output, set the subwoofer's Crossover Filter switch to Off.

Volume Control

Initially, set the subwoofer's volume knob to the 11 o'clock position. During normal operation you will use the receiver's subwoofer volume control to change the subwoofer volume. (This is much more convenient than having to reach behind the subwoofer to turn its volume knob every time you want to adjust its volume.) If the receiver's subwoofer volume control won't go loud or soft enough, re-adjust the subwoofer's volume knob to compensate. See the receiver's instruction manual for details on using the receiver's subwoofer volume control.

Balancing the Speakers

You can use your ears to balance the volume levels of all the system's speakers for your room and listening position. When all of the speakers are set at the same volume level, your system will create a more realistic, spacious surround sound environment.

1. Sit in the seat where you will be watching movies. Eliminate as many external noises as possible.
2. Turn the receiver's volume control up to between -20dB and -25dB. For greatest accuracy, the level balancing should be done at a moderately loud listening level.
3. Press the **SETUP** button on the remote five times. The receiver's display will read **Lch 0dB**, the left speaker icon will flash and you will hear test noise circulate from speaker to speaker. (The display will change and the speaker icons will flash to indicate which speaker is playing the test noise.)
4. Using the left front speaker as a reference, carefully listen to the volume level of the noise through each speaker. If the noise is much louder or softer through one speaker than it is through the left front speaker, wait until the display shows that speaker and press one of the **MULTI CONTROL** buttons on the remote. The test noise will stay in that speaker. Using the **MULTI CONTROL** buttons, adjust the speaker's volume until it's the same as the left front speaker.
5. Repeat Step 4 for each speaker **except the subwoofer** until they all play at the same volume level. Fine-tune the levels as necessary.
6. Due to the way humans hear, the test noise through the subwoofer will not sound as loud as it really is. Because of this, you cannot use the test noise to properly set the level of the subwoofer. To set the subwoofer level, listen to familiar music or films that have strong bass content and adjust the subwoofer level until it sounds balanced with the rest of the speakers. (The subwoofer test noise is designed to be used with a sound pressure level meter for balancing.)
7. Do not be concerned with the volume setting number readout on the display while you're doing the balancing—this is for reference purposes only. Once you have balanced all the speakers you should write each speaker's volume setting down for reference.

Setting the Speaker Distances

This last step adjusts the timing of all the speakers so that their sound arrives at the listening location at the proper time.

1. Measure the distance from each speaker to your seat. Write the distances down.
2. Press the **SETUP** button on the remote six times. The display will read **1.0FT 3.0M**, and the left and right speaker icons will flash.
3. Press the **MULTI CONTROL** buttons until the display matches the distance from your left and right speakers to your listening position. (Each 0.3 meter increment equals one foot.)
4. Press the **SETUP** button again and repeat step 3 for the center speaker, and again for each surround speaker.
5. When you've finished setting the speaker distances, press the **SETUP** button once to exit the setup mode.

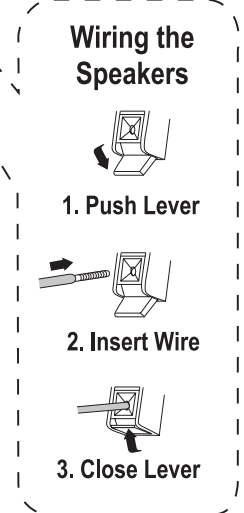
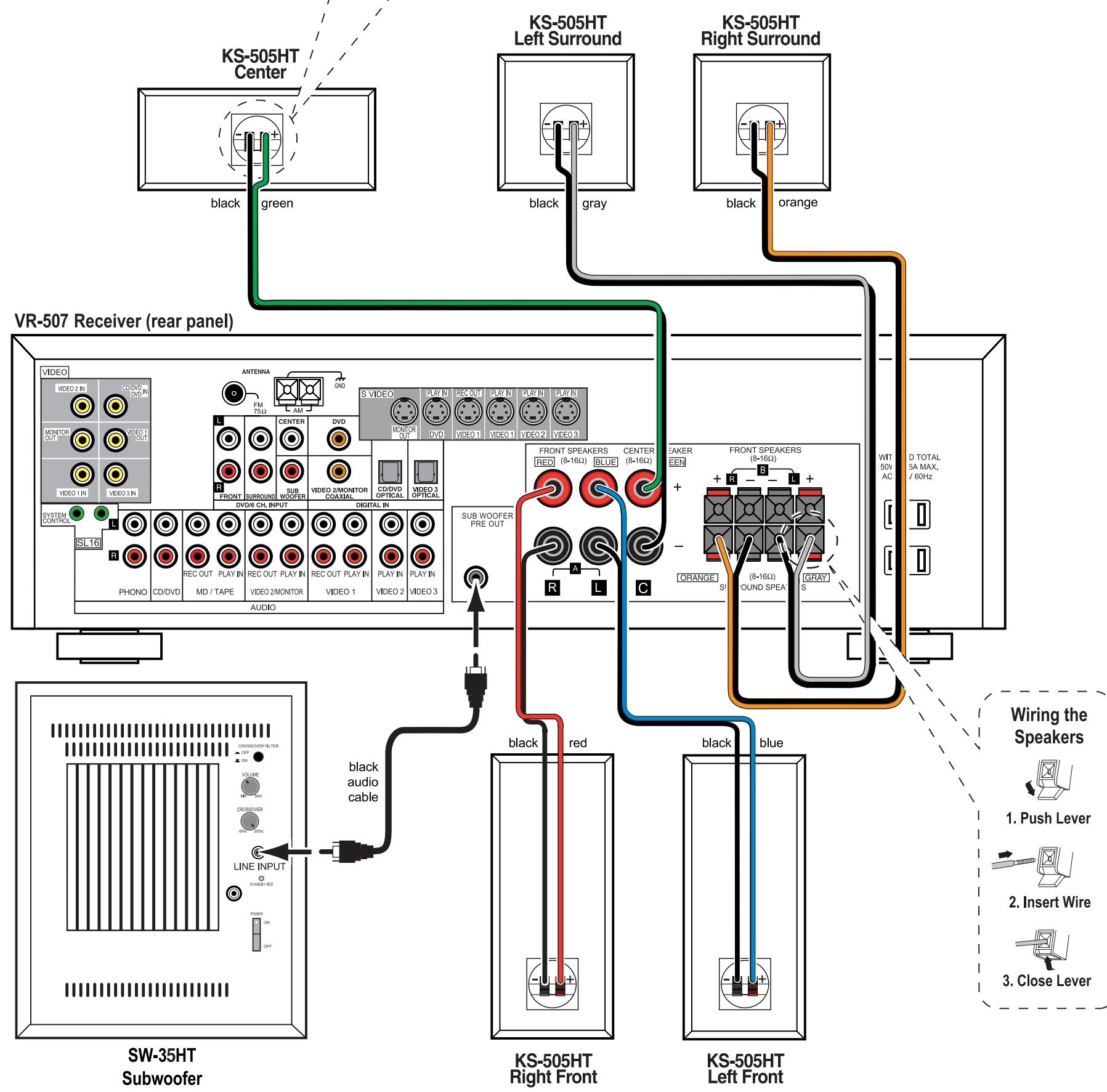
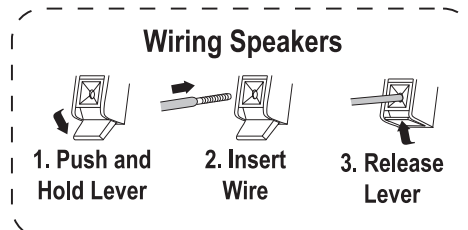

Congratulations!

The HTB-404 Home Theater System will make watching movies at home more fun than ever. To connect your speakers to the receiver follow the instructions on this sheet. To learn how to operate your receiver please read and follow the instruction manual included in the receiver's box. If you're also connecting other equipment, such as a TV, VCR, DVD player, CD player or other source component, use the receiver's manual in combination with the manuals that came with those components.

Placing Your Speakers

Place the speakers as shown in the diagram below. While you're setting the speakers up, keep these points in mind:

- If the subwoofer causes discoloration of the TV picture, move it away from the TV until the discoloration disappears.
- Since the left, center and right speakers are magnetically shielded, you can place them right on top of and next to the TV without worrying about picture discoloration.
- You can hang the surround speakers on the wall using heavy-duty picture-hangers.
- Placing the subwoofer next to a wall yields more deep bass output than placing it away from a wall. Placing the subwoofer in a corner yields the deepest bass output overall.

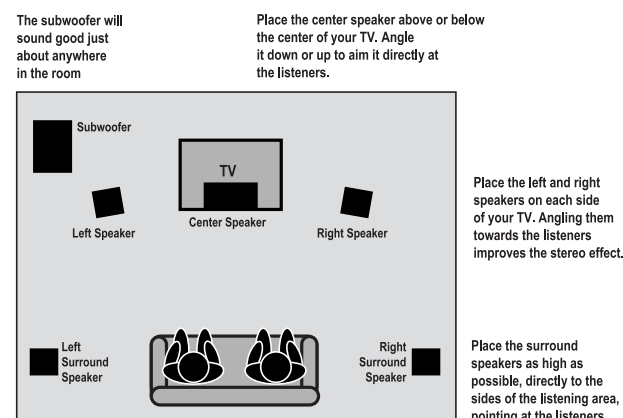

Connecting Your Speakers

Important: Do not plug the receiver's power cord into an AC outlet until you have properly connected all of the speakers.

Connect the speakers as shown in the main diagram. To make connecting the speakers easier, we have color-coded the speaker wire and the terminals on the speakers, labeled the terminals on the receiver, and pre-stripped the insulation from the ends of the wire.

In each case, connect the colored speaker wire to the same color terminal on the speaker and the red terminal on the receiver, and connect the black speaker wire to the black terminal on the speaker and receiver. (Since the terminal on the subwoofer is not color-coded, connect the brown speaker wire to the red terminal on both the subwoofer and the receiver.)

Balancing the Speakers

You can use your ears to balance the volume levels of all the system's speakers for your room and listening position. When all of the speakers are set at the same volume level, your system will create a more realistic, spacious surround sound environment.

1. Sit in the seat where you will be watching movies. Eliminate as many external noises as possible.
2. Turn the receiver's volume control up to between -20dB and -25dB. For greatest accuracy, the level balancing should be done at a moderately loud listening level.
3. Press the **SETUP** button on the remote five times. The receiver's display will read **Lch 0dB**, the left speaker icon will flash and you will hear test noise circulate from speaker to speaker. (The display will change and the speaker icons will flash to indicate which speaker is playing the test noise.)
4. Using the left front speaker as a reference, carefully listen to the volume level of the noise through each speaker. If the noise is much louder or softer through one speaker than it is through the left front speaker, wait until the display shows that speaker and press one of the **MULTI CONTROL** buttons on the remote. The test noise will stay in that speaker. Using the **MULTI CONTROL** buttons, adjust the speaker's volume until it's the same as the left front speaker.
5. Repeat Step 4 for each speaker until they all play at the same volume level. Fine-tune the levels as necessary.
6. Do not be concerned with the volume setting number readout on the display while you're doing the balancing—this is for reference purposes only. Once you have balanced all the speakers you should write each speaker's volume setting down for reference.
7. Press the **SETUP** button on the remote four times to exit the setup mode.

Setting the Speaker Distances

This last step adjusts the timing of all the speakers so that their sound arrives at the listening location at the proper time.

1. Measure the distance from each speaker to your seat. Write the distances down.
2. Press the **SETUP** button on the remote six times. The display will read **10FT 3.0M**, and the left and right speaker icons will be flashing.
3. Press the **MULTI CONTROL** buttons until the display matches the distance from your left and right speakers to your listening position. (Each 0.3 meter increment equals one foot.)
4. Press the **SETUP** button again and repeat step 3 for the center speaker, and again for each surround speaker.
5. When you've finished setting the speaker distances, press the **SETUP** button once to exit the setup mode.

(HTB-504 Quick-Connect Guide on other side)

